

SSX Series

Serial Memory Extended Tokens



The power of memory. Secured.

The SSX series of extended SlimLine™ memory tokens are ergonomic 2Kb to 256Kb memory devices that provide convenient data storage and transfer for high-volume, end-user applications. Each SSX extended token contains a non-volatile, serial SPI¹ EEPROM that can be read, erased and written using a SlimLine receptacle, which is available in panel-mount and board-mount forms or SlimLink™ programmers that can easily interface to PCs and other hardware via a standard RS-232 or USB port. A thin profile and space-saving interface connection make them especially well suited for use in compact systems. The token is molded using a rugged composite, which protects the embedded memory from harsh environmental influences, so it retains data even when exposed to dirt, moisture, chemicals, X-rays and up to 15kV of electrostatic discharge. The token design features a redundant contact system, ensuring maximum reliability. Customization options are available, including color-matching and custom logos.



For pin-out information, refer to the individual datasheets for the SR4000 family of receptacles.

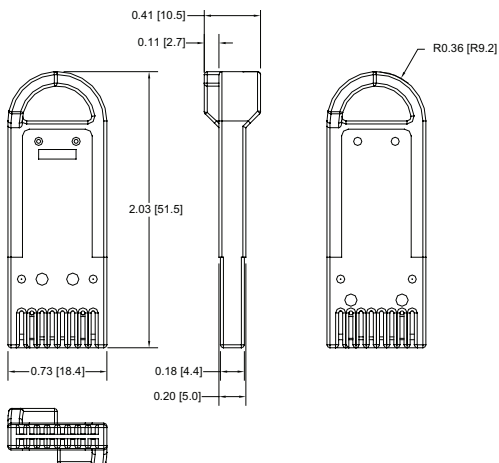

Drawing dimensions are in inches and millimeters [mm]. Dimensions are nominal and subject to manufacturer's tolerances.

MECHANICAL	
Contact Life	10,000 Insertions/Removal Cycles Min.
Contact Arrangement	Fully Redundant (Front:Back)
ELECTRICAL ¹	
Power, Active	25 mW at 5 V Typical
Power, Standby	50 μW at 5 V Typical
Voltage ³	2.7 to 5.5 V
ESD Protection	15 kV (per Std. 064-1028)
ENVIRONMENTAL	
Storage Temperature	-40°C to + 100°C
Operating Temperature	-40°C to + 85°C
Relative Humidity	5% to 95% (non-condensing)
MEMORY ¹	
Token:	Capacity:
SSX2Kb	2Kb (2,048 bits) 256 x 8
SSX16Kb	16Kb (16,384 bits) 2048 x 8
SSX64Kb	64Kb (65,536 bits) 8192 x 8
SSX256Kb	256Kb (262,144 bits) 32768 x 8
Read Cycles	Unlimited
Write/Erase Cycles	1,000,000 Cycles Minimum ⁴
Data Life (Storage)	10 Years Minimum
MATING COMPONENT(S)	
Panel-Mount Receptacle	SR4210
PCB Mount Receptacle	SR4000 Family of Receptacles
Reader/Writer	SlimLink™ III (recommended), SlimLink™ II
ORDERING INFORMATION ²	
SSX2Kb	611-0121-00xA
SSX16Kb	611-0122-00xA
SSX64Kb	611-0123-00xA
SSX256Kb	611-0124-00xA

- 1: Complete interface specification available at www.datakey.com
- 2: "x" indicates optional color number. "A" suffix on part number indicates RoHS compliance. See CE declaration below for details.
- 3: It is recommended that all new key/token implementations be designed to operate with power supplies in the range of 2.7 to 3.6 volts. Although there are no immediate difficulties in procuring memory devices that operate in the 4.5 to 5.5 volt range, future availability may be impacted as semiconductor manufacturers shrink their die geometries.
- 4: SSX256Kb tokens manufactured prior to 2007 have a 100,000 write/erase cycle minimum.



NOTES: Conforms with Directive 2011/65/EU of the European Parliament and of the Council of 8 June 2011, and as amended by Directive 2015/863/EU, on the restriction of the use of certain hazardous substances in electrical and electronic equipment.

WARNING: Cancer and Reproductive Harm - www.P65Warnings.ca.gov

221-0135-000 Rev. E 4/19

View our full product line at www.datakey.com

ATEK Access Technologies
10025 Valley View Road, Ste. 190
Eden Prairie, MN 55344 U.S.A.

PH: 1.800.523.6996
FAX: 1.800.589.3705
+1.218.829.9797

www.atekaccess.com



Access the power of technology.